

M.SA 02-08

2 - Hood

CODE	DESCRIPTION
160704	BLACK PLUG WITH GASKET 1/2"GAK
160788	PLUG
160789	NUT
180108	PLASTIC NUT 1/2"
200870	GASKET 18X10X2
210207	FOOT BHC
322896	HOOD GF70
351896	FRONT PANEL GF70
450821	SPRING CLIP FASTENER SNU 3634
H25693	REPLACED BY 260702
H25744	REPLACED BY 260503
H25791	REPLACED BY 260414
H33408	GASKET FOR FRONT PANEL GF70
H33749	CABLE HOLDER GF70
H34332	JOINT
H36580	HOOD GF70
H36585	RIGHT GUIDE FOR RACK GF70
H36586	LEFT GUIDE FOR GF70 RACK
H36589	BACK PANEL GF70
H36590	LOWER PANEL GF70
H36653	REPLACED BY 450519
H36654	REPLACED BY 270101
H36828	SUPPORT
H36920	REPLACED BY 260126
H36926	GF70 DOOR GASKET
H37265	DOOR GASKET SCREW

3 - Door component

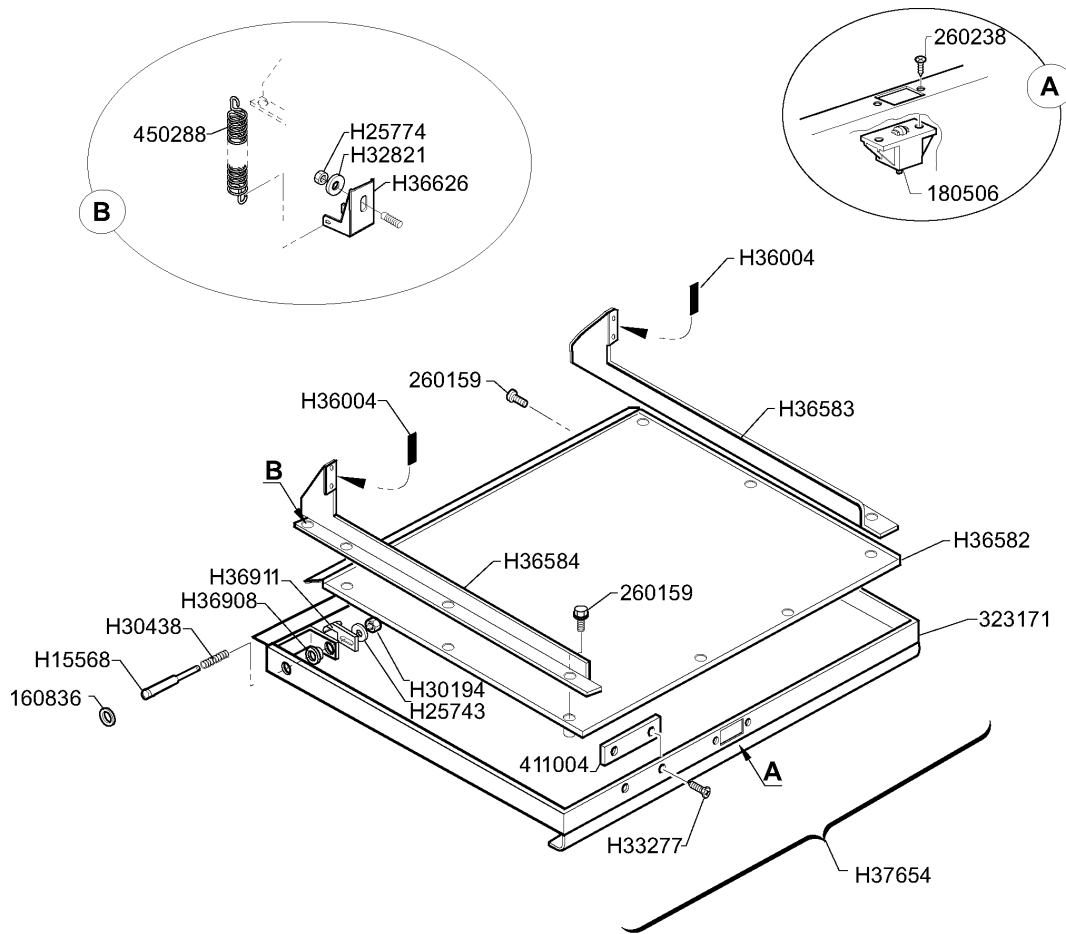

M.SA 07-10

3 - Door component

CODE	DESCRIPTION
160836	DOOR WASHER BR-BC-FC
180506	DOOR CATCH BR-BC-FC
260159	SCREW
260238	M4 X 10 MUSH/HD SCREW
323171	DOOR FRONT PANEL GF70
411004	PERMANENT MAGNET FOR MICROSUIT
450288	DOOR SPRING
H15568	DOOR PIN FOR DOOR GF70/90
H25743	REPLACED BY 260502
H25774	REPLACED BY 260403
H30194	REPLACED BY 260418
H30438	SPRING
H32821	REPLACED BY 260503
H33277	SCREW TSP 2,9X9,5
H36004	PAD FOR DOOR GF90
H36582	DOOR PANEL GF70
H36583	RIGHT GUIDE FOR GF70 DOOR
H36584	LEFT GUIDE FOR DOOR GF70
H36626	LF DOOR SPRING BRACKET
H36908	BUSH
H36911	PLATE
H37654	DOOR GF70

4 - Control box

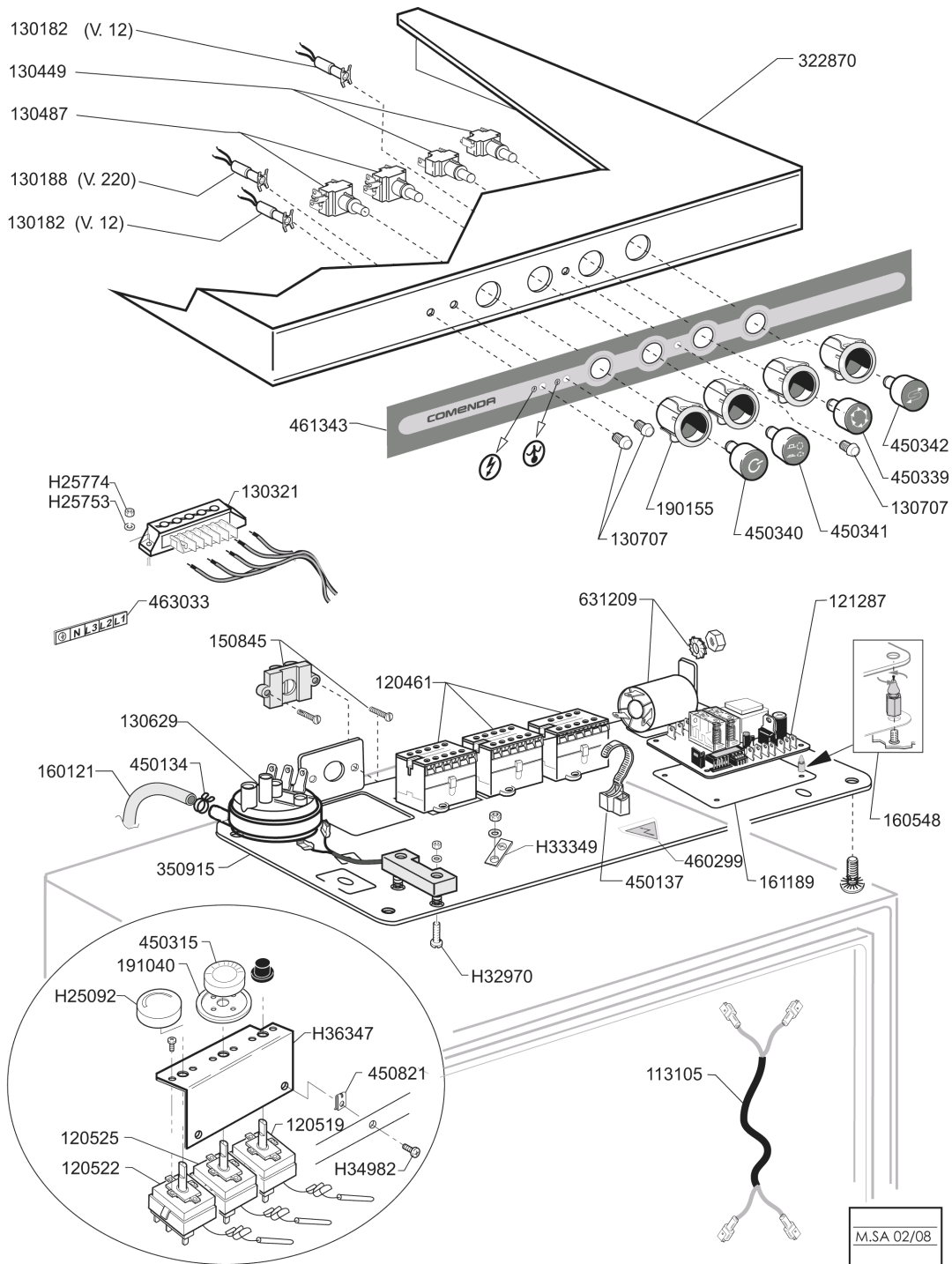

4 - Control box

CODE	DESCRIPTION
113105	CABLE FOR SOFTENER
120461	CONTACTOR ABB B6-30-01 220V
120519	SECURITY THERMOSTAT 95-125Ø
120522	TANK THERMOSTAT 90Ø
120525	BOOSTER THERMOSTAT 2 TEMPERAT.
121287	ELECTRONIC TIMER
130182	GREEN LAMP 12V
130188	GREEN LED 220V
130321	JUNCTION BOX 6 CONNECTORS
130449	PUSH BUTTON BR-BC-FC
130487	SWITCH
130629	PRESSURE SWITCH 1L30-12
130707	TRANSPARENT LENS COVERS (C-SER
150845	PRESSACAVO SERIM 4228B
160121	HOSE EPDM D. 5 X 9
160548	DISTANZ.TASTIERINI ELETTRONICI
161189	COVER
190155	BUTTON HOLDER
191040	FRAME F.THERMOSTAT KNOB
322870	HOOD GF70 WITH SOFTENER
350915	CONTROL PANEL SUPPORT
450134	ELASTIC HOSE CLIP D.9,3/8,8
450137	COLLAR CONNECTION WITH BASE 31
450315	KNOB F. THERMOSTAT 90Ø
450339	PUSH BUTTON "CYCLE"
450340	PUSH BUTTON
450341	PUSH BUTTON
450342	REGENERATION SWITCH
450821	SPRING CLIP FASTENER SNU 3634
460299	TARGH.ADES.TENSIONE
461343	PLATE LF2004/SOFTENER
463033	TARGHETTA PER MORSETTIERA
631209	ANTI-NOISE FILTER
H25092	KNOB FOR THERMOSTAT GF70
H25753	REPLACED BY 260511
H25774	REPLACED BY 260403
H32970	REPLACED BY 260307
H33349	REPLACED BY 460121
H34982	REPLACED BY 260248
H36347	THERMOSTATS BRACKET GF70

5 - Rinse assembly

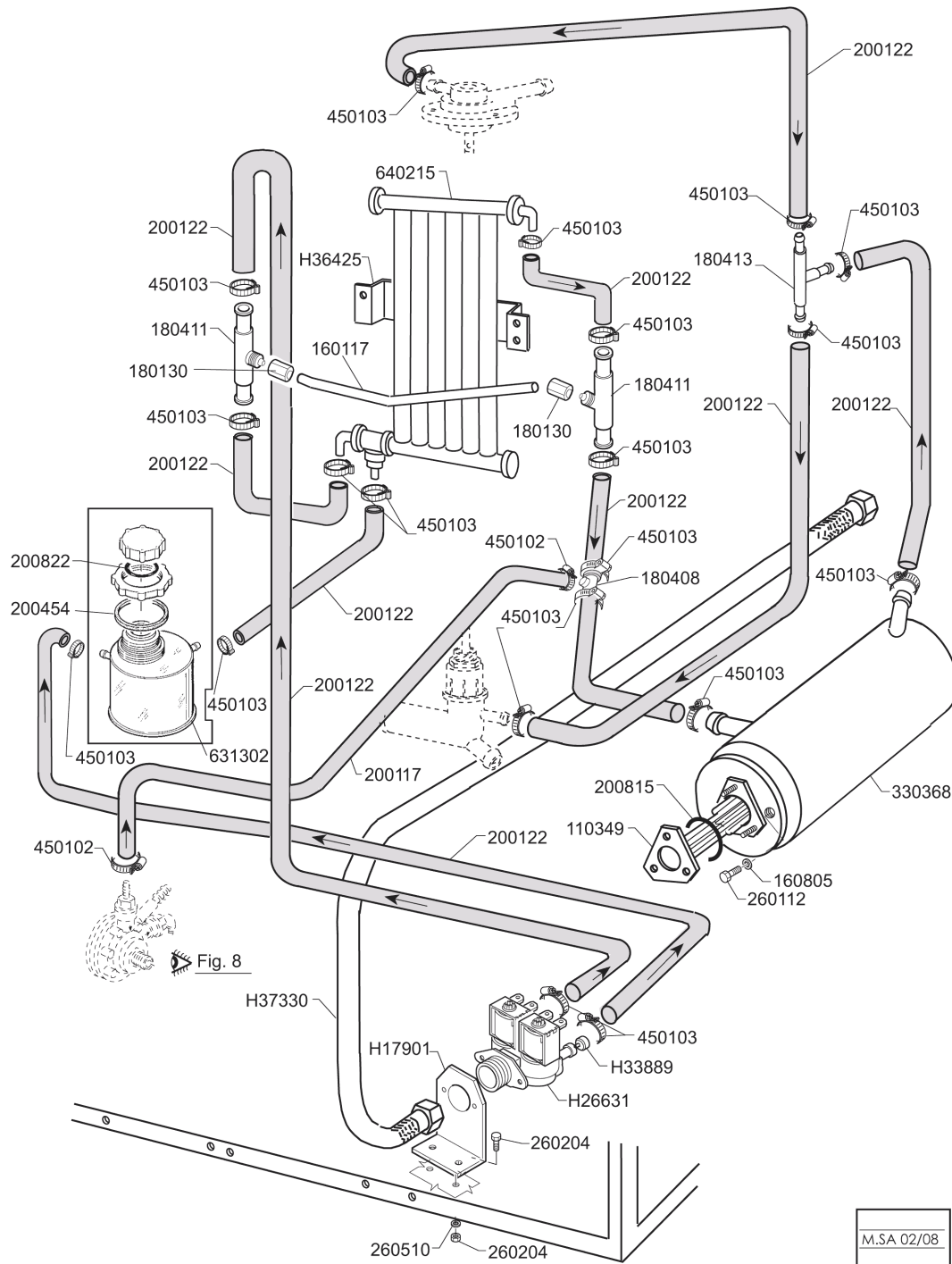

5 - Rinse assembly

CODE	DESCRIPTION
110349	HEAT.ELEMENT 6000W 230/400V
160117	HOSE 6,3X1,1 WITHE
160805	GASKET D.8
180130	CONNECTION NUT FOR BY PASS (1/
180408	TEE-NIPPLE F.INJECT.W/CENTR.RE
180411	TEE-NIPPLE FOR BY PASS "BTM"
180413	TEE NIPPLE D.11,5 - RINSE ASSE
200117	RUBBER HOSE 7X16
200122	HOSE 11X19
200454	GASKET F. SALT CONT.
200815	O-RING F. HEAT.ELEM.
200822	PLUG GASKET OF SALT CONTAINER
260112	STAINLESS STEEL TE-SCREW 8X16
260204	SCREW TCP 4X10
260510	GROWER WASHER D.4
330368	BOILER LF2004
450102	CLAMP FE ZN 11-17 H=9
450103	CLAMP FE ZN. 13-20 H=9
631302	SALT CONTAINER
640215	WATER SOFTENER GF70
H17901	REPLACED BY 330725
H26631	2-WAY SOLENOID VALVE GF90
H33889	RIDUTT.ELETTROV.RIGENER.GF90A
H36425	SUPPORT FOR SOFTENER
H37330	REPLACED BY 200715

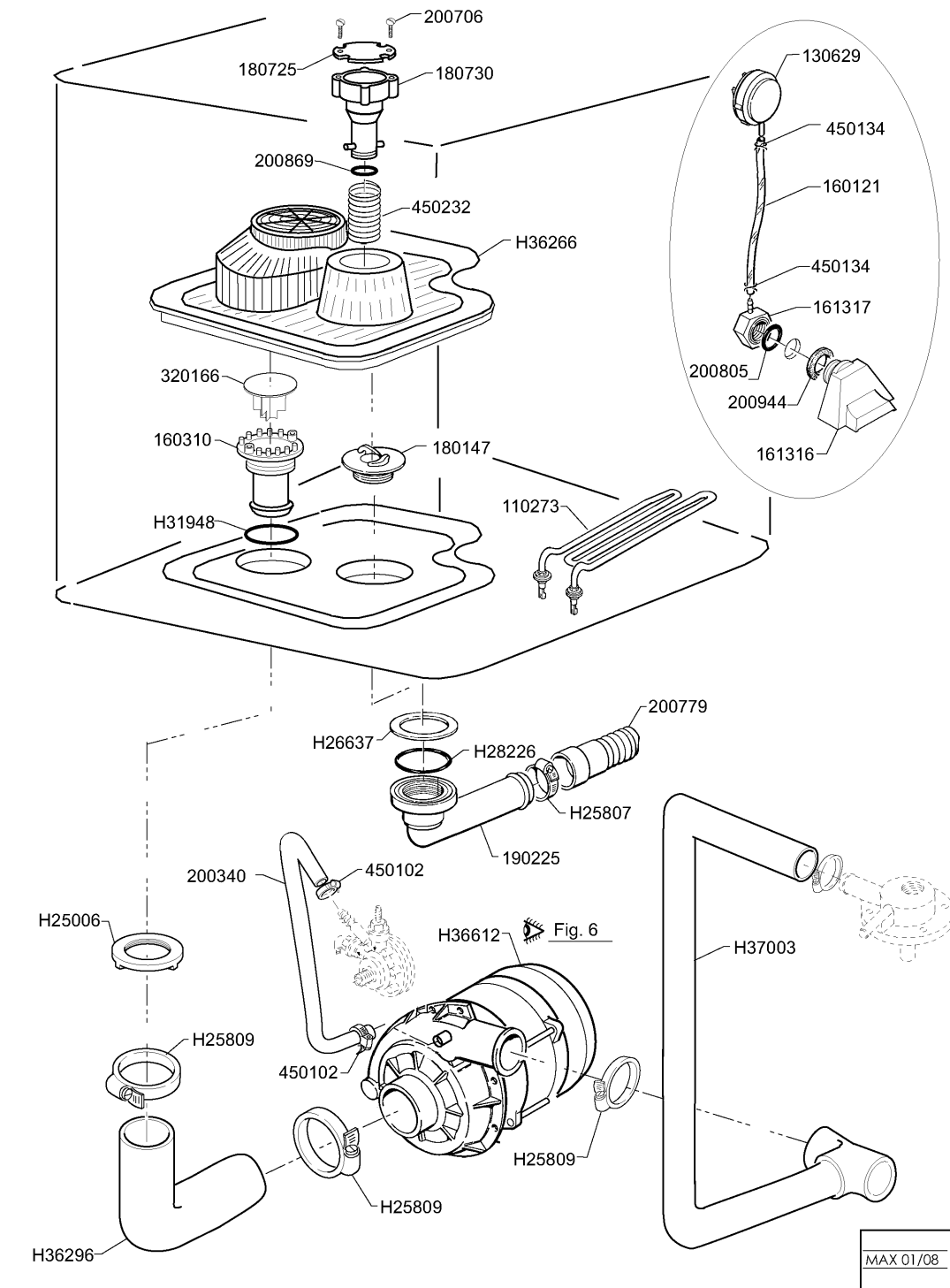

6 - Tank

CODE	DESCRIPTION
110273	TANK HEATER 2000W 230V
130629	PRESSURE SWITCH 1L30-12
160121	HOSE EPDM D. 5 X 9
160310	INLET HOSE BHC
161316	AIR TRAP
161317	NUT FOR AIR TRAP
180147	NUT
180725	OVERFLOW PIPE COVER
180730	OVERFLOW PIPE
190225	DRAIN OUTLET
200340	SALT CONTAINER HOSE B25-7-12
200706	RINSE HOSE
200779	DRAIN HOSE FOR BR-BC-FC43
200805	OR GASKET 2,62X28,24X33,48
200869	GASKET
200944	GASKET
320166	VORTEX BREAKER FOR FC MACHINES
450102	CLAMP FE ZN 11-17 H=9
450134	ELASTIC HOSE CLIP D.9,3/8,8
450232	SPRING
H25006	NUT FOR HOSE H26556
H25807	REPLACED BY 450105
H25809	CLAMP 40-64
H26637	REPLACED BY 460507
H28226	REPLACED BY 200867
H31948	REPLACED BY 200842
H36266	REPLACED BY 180831
H36296	PUMP INLET HOSE GF70
H36612	WASH PUMP GF70
H37003	PUMP OUTLET HOSE GF70

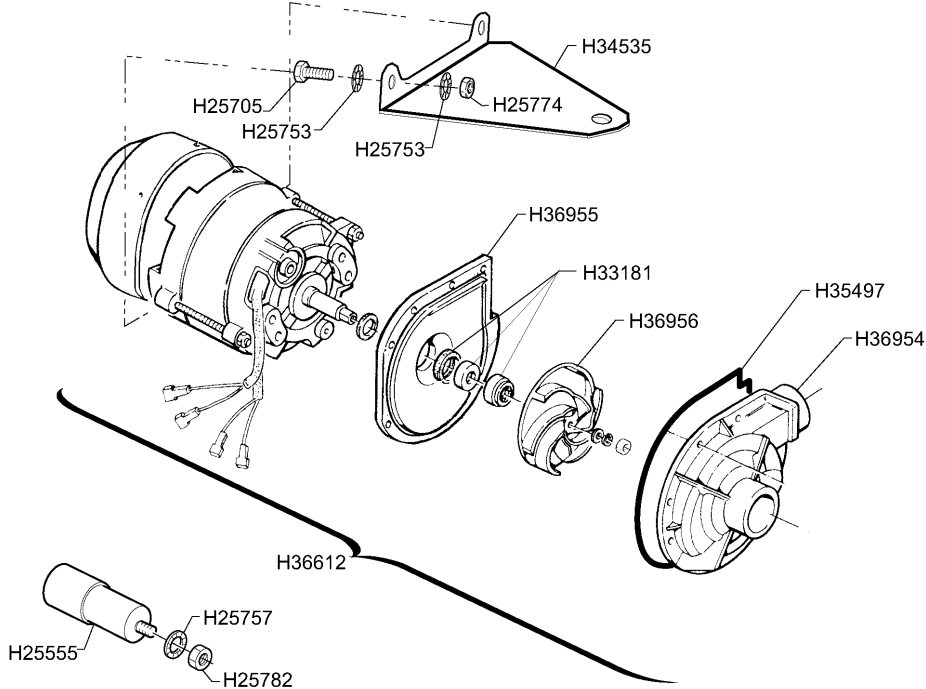

M.SA 02-08

7 - Pump

CODE	DESCRIPTION
H25555	REPLACED BY 631207
H25705	REPLACED BY 260139
H25753	REPLACED BY 260511
H25757	S/S FLAT WASHER
H25774	REPLACED BY 260403
H25782	STAINLESS STEEL NUT 8MA
H33181	GF70 WASH PUMP SEAL
H34535	GF70 PUMP BRACKET
H35497	GF70 WASH PUMP GASKET
H36612	WASH PUMP GF70
H36954	GF70 WASH PUMP VOLUTE
H36955	GF70 WASH PUMP FLANGE
H36956	GF70 PUMP IMPELLER

8 - Wash arm

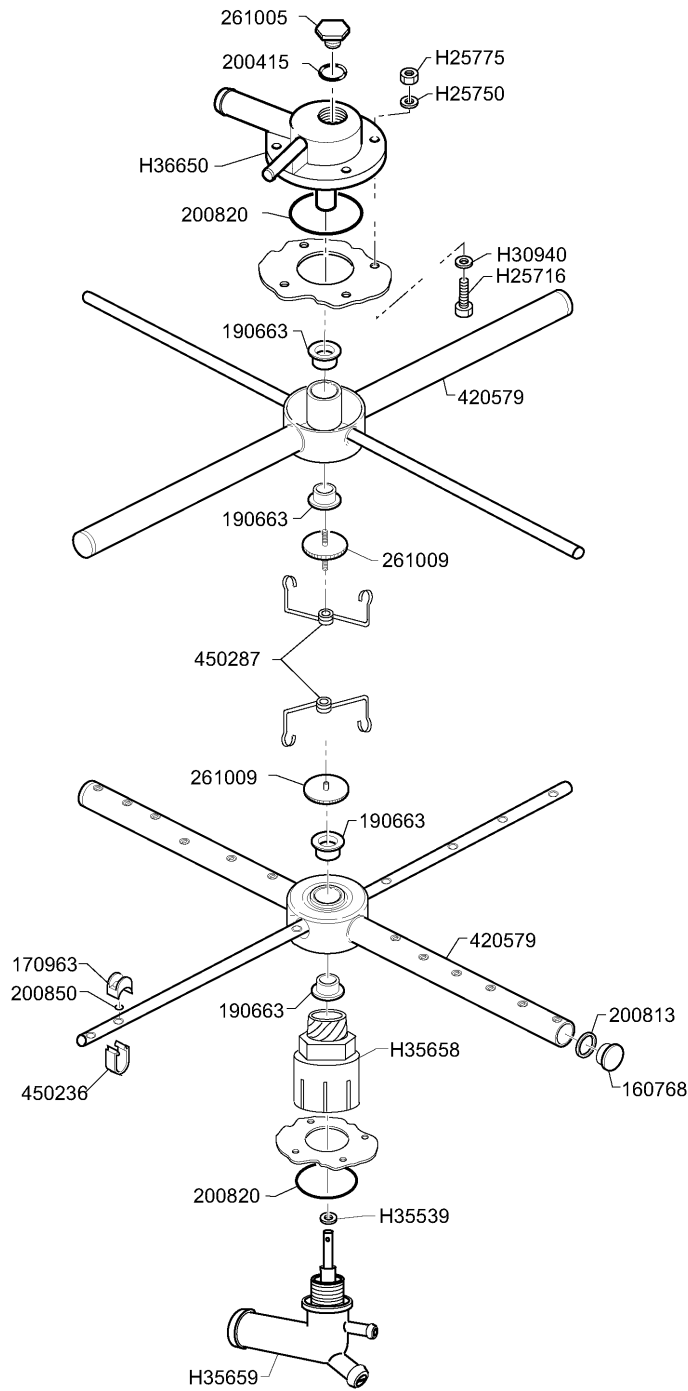

M.SA 02-08

8 - Wash arm

CODE	DESCRIPTION
160768	PLUG FOR "C95-155" WASH ARM
170963	RINSE JET X FC
190663	BUSH
200415	AIR TRAP GASKET -F2 18,5X10X3
200813	OR GASKET 2,21X16,36X20,78
200820	O-RING151 46,99X5,33X57,6
200850	O-RING
261005	SCREW F. TEE UP.WASH F2-B41
261009	RETAIN.SCREW FOR WASH-RINSE AR
420579	WASH AND RINSE ARM GF70
450236	SPRING FOR WASHER 170963
450287	ARM SPRING GF70
H25716	REPLACED BY 260105
H25750	REPLACED BY 260512
H25775	REPLACED BY 260416
H30940	REPLACED BY 260504
H35539	GF70 BUSH FOR LOWER ARM SUPP.
H35658	GF70 LOWER WASH ARM SUPPORT
H35659	GF70 LOWER ARM SUPPORT
H36650	GF70 UPPER ARM SUPPORT

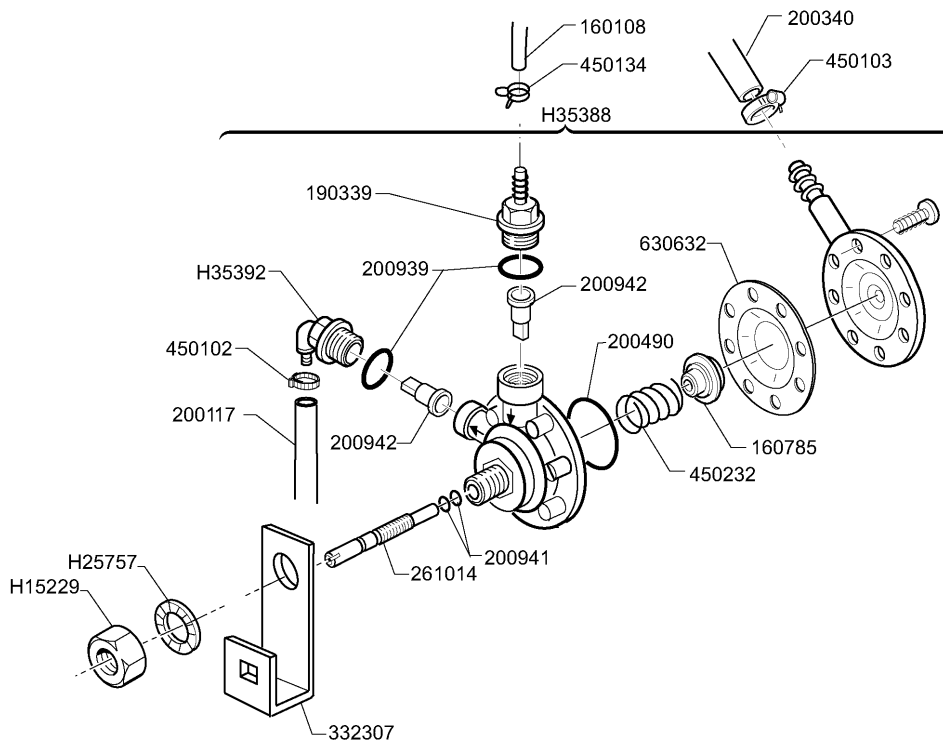

M.SA 02-08

9 - Rinse

CODE	DESCRIPTION
160108	INJECT.INLET HOSE D.8X5
160785	GUIDE FOR SPRING RINSE AID INJ
190339	RINSE AID INJECTOR CONNECTION
200117	RUBBER HOSE 7X16
200340	SALT CONTAINER HOSE B25-7-12
200490	PROTECTION GASKET MOD.ADV.
200939	OR GASKET
200941	OR GASKET
200942	VALVE RINSE INJECTOR HVD
261014	SCREW
332307	BRACKET
450102	CLAMP FE ZN 11-17 H=9
450103	CLAMP FE ZN. 13-20 H=9
450134	ELASTIC HOSE CLIP D.9,3/8,8
450232	SPRING
630632	DIAPHRAGM RINSE INJECTOR HVD
H15229	NUT
H25757	S/S FLAT WASHER
H35388	RINSE AID INJECTOR GF70/FC-E
H35392	NIPPLE

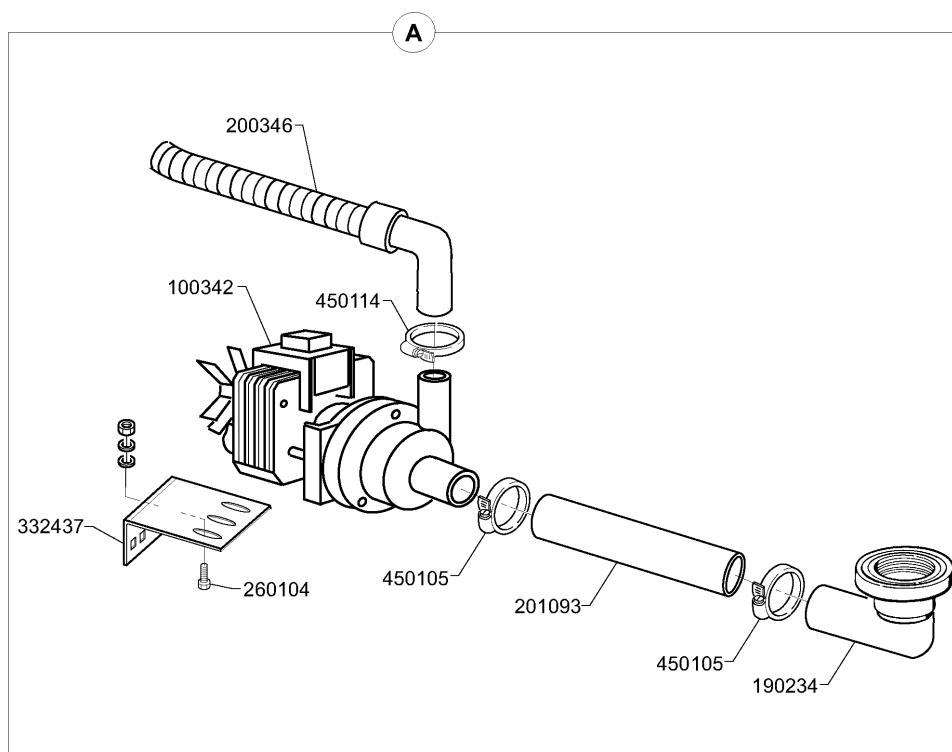
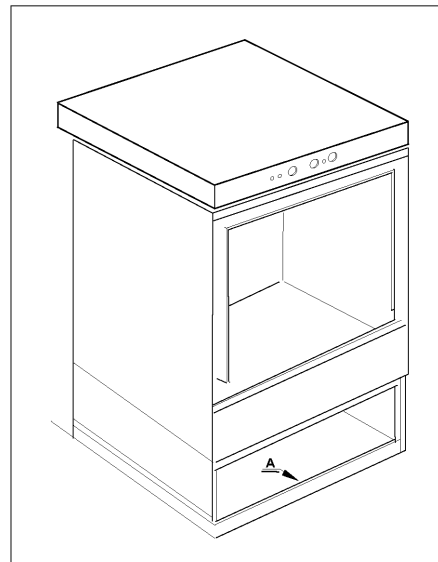

M.SA 02-08

10 - Drain pump

CODE	DESCRIPTION
100342	DRAIN PUMP 100 W 220V
190234	DRAIN OUTLET
200346	DRAIN HOSE GLASSWASHER
201093	HOSE 28X36X136 GF70
260104	STAINL.ST TE-SCREW A2 6X16 UNI
332437	BRACKET
450105	CLAMP FE ZN. 26-38 H=12,2
450114	CLAMP FE ZN.22-32 H=12,2

11 - Detergent pump

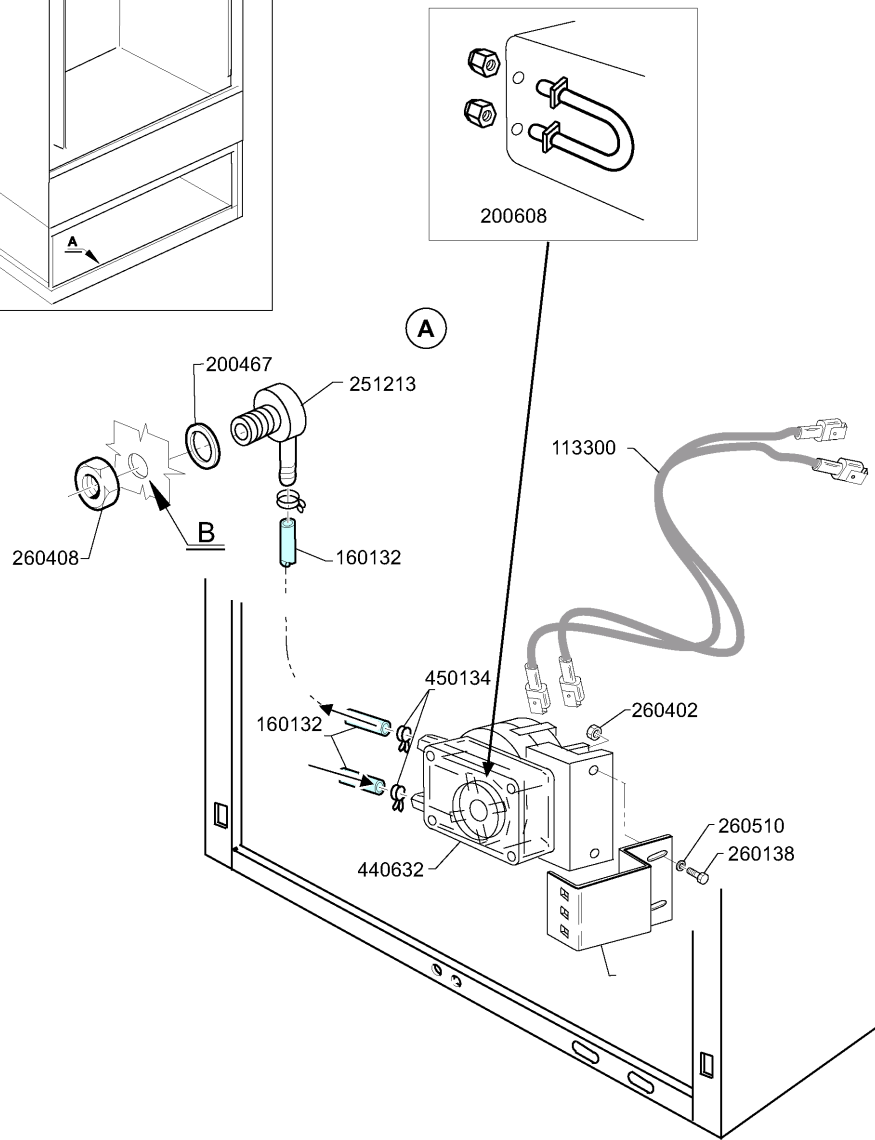
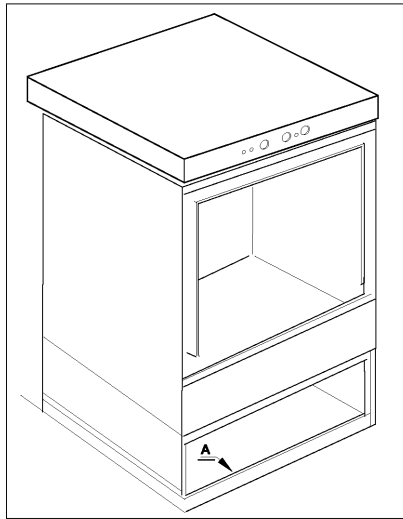

M.SA 04/09

11 - Detergent pump

CODE	DESCRIPTION
113300	CABLE FOR DETERGENT INJECTOR
160132	HOSE 5X7
200467	DUTRAL GASKET F. AIR TRAP
200608	DETERGENT DISPENSER HOSE
251213	INJECTIOR S/S FOR DETERGENT IN
260138	SCREW TE 4X10
260402	STAINLESS STEEL NUT D4 UNI 55
260408	S/S NUTS D.12
260510	GROWER WASHER D.4
440632	DETERGENT INJECTOR
450134	ELASTIC HOSE CLIP D.9,3/8,8